



Item No. \_\_\_\_\_

# C707

## Soft Serve Freezer

Single Flavor

### Features

Offers all the popular soft serve variations, from low or non-fat ice creams to custards, yogurt, and sorbet.

### Freezing Cylinder

One, 3.4 quart (3.2 liter).

### Mix Hopper

One, 20 quart (18.9 liter). Separate hopper refrigeration (SHR) maintains mix below 41°F (5°C) during Auto and Standby modes.

### Indicator Lights

Mix Low light alerts operator to add mix. Audible alarm may be enabled to sound when mix is low. When the Mix Out light flashes, the unit shuts down automatically to prevent damage.

### Electronic Controls

Softech™ is our exclusive microprocessor-based master control that regulates refrigeration by measuring product viscosity to maintain consistent quality.

### Standby

During long no-use periods, the Standby feature maintains safe product temperatures in the mix hopper and freezing cylinder.

### Digital Temperature Indicator

Hopper temperature is displayed to ensure safe product temperatures. Indicator may be switched from Fahrenheit to Celsius temperature display.

### Door Interlock System

Protects the operator from injury as the beater will not operate without the dispensing door in place.

C707



Optional cart with front opening door



Optional cart with rear door for front mount syrup rail



Optional top air discharge chute

750 N. Blackhawk Blvd. Rockton, Illinois 61072  
800-255-0626  
Phone 815-624-8333 Fax 815-624-8000  
[www.taylor-company.com](http://www.taylor-company.com)  
info@taylor-company.com

ISO 9001:2015  
Registered Firm



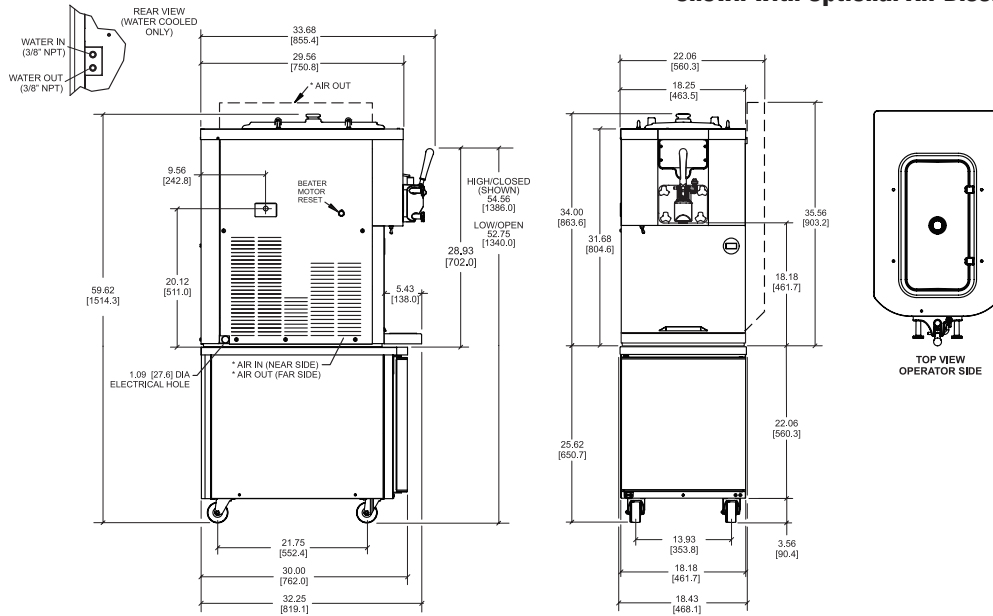

NOTE: \* (AIR COOLED ONLY) FIGURES IN BRACKETS INDICATE MILLIMETERS / DECIMAL AND FRACTIONAL DIMENSIONS EQUAL TO ( PLUS OR MINUS 1/16 INCH [1.5mm] ).

Weights	lbs.	kgs.
Net	390	176.9
Crated	412	186.9

\*For reference only

	cu. ft.	cu. m.
Volume	35.0	0.99

Dimensions	in.	mm.
Width	18-1/4	464
Depth	32-1/4	819
Height	34	864

\*Designed to rest on a plastic pad directly on the countertop or optional cart.

Electrical	Maximum Fuse Size	Minimum Circuit Ampacity	Poles (P) Wires (W)
208-230/60/1 Air	25	20	2P 3W
208-230/60/1 Water	25	20	2P 3W
208-230/60/3 Air	15	13	3P 4W
220-240/50/1 Air	20	18	2P 3W
380-415/50/3N~ Air	8	7	4P 5W

This unit may be manufactured with other electrical characteristics and may have additional regulatory agency approvals. Consult the local Taylor distributor for other electrical characteristics and agency approvals based on specific electrical and country requirements.

(For exact electrical information, approval marks, and refrigerant, always refer to the data label of the unit.)

**Continuing research results in steady improvements; therefore, these specifications are subject to change without notice.**

**Bidding Specs**

Electrical: Volt \_\_\_\_\_ Hz \_\_\_\_\_ ph \_\_\_\_\_  
 Neutral: Yes No Cooling: Air Water NA

Options: \_\_\_\_\_

**Specifications**

**Electrical**

One dedicated electrical connection is required. See the electrical chart for the proper electrical requirements. Manufactured to be permanently connected. Consult your local Taylor distributor for cord and receptacle specifications as local codes allow.

**Beater Motor**

One, 1.5 hp.

**Refrigeration System**

One, 10,100 BTU/hr. R449A.  
 Separate Hopper Refrigeration (SHR), one, 400 BTU/hr. R134a. (BTUs may vary depending on compressor used.)

**Air-Cooled**

Minimum 6" (152 mm) on both sides and place the back of the unit against a wall to prevent recirculation of warm air. Minimum air clearances must be met to ensure adequate airflow for optimum performance. Optional air discharge chute directs heated air exhaust upward. No clearance required on right side if air discharge chute is used.

**Water-Cooled**

Water inlet and drain connections out rear panel 3/8" FPT.

**Options**

- Cone Dispenser
- Hopper Locks
- Legs - Increase height of unit by 4-1/4" (108 mm)
- Syrup Rail (front mount requires special cart with rear door)
- Syrup Rail Kit (side mount)
- Hopper Agitator
- Top Air Discharge Chute (air-cooled only)
- C201 Cart, Standard Height with Casters
- C201 Cart, Standard Height with Casters, Flavor Burst Ready
- C201 Cart, Standard Height with Casters, Rear Door

All options may not be available in combination with others or with all electrical or cooling configurations. Please consult your local Taylor distributor.

Authorized Taylor Distributor



750 N. Blackhawk Blvd.  
 Rockton, Illinois 61072  
 www.taylor-company.com